

## Product Datasheet



The global certified SLK-800-C is a non-isolated extremely wide input smart LED driver. 10kV surge protection level, 100khour long life and 5-year warranty provide high confidence to luminaire users. It supports not only traditional 4-in-1 control, but also DALI2.0 and other protocols. NFC and cable programming are both available. All around protections including digital OTP (internal and external by NTC) with auto-recovery secure 24hour non-stop operation for luminaires.

- Stadium
- Horticultural
- Flood
- Harbor
- UV
- Fishing



- Features ..... 2
- Model List ..... 2
- Technical Data ..... 3
- Safety/EMC Compliance ..... 4
- Dimming ..... 4
- Programming ..... 6
- Lifetime vs. Case Temperature ..... 8
- Power Factor vs. Load ..... 8
- THD vs. Load ..... 9
- Efficiency vs. Load ..... 9
- Inrush Current ..... 11
- Dielectric Strength ..... 11
- Tc Point ..... 12
- Packaging Information ..... 12
- Mechanical Design ..... 13
- Output Operation Range ..... 16
- Revision History ..... 17

## ■ Features

- Absolute Supply Voltage: 180-528Vac
- 97% Efficiency Max.
- <1% Low Frequency Ripple
- Fast Dimming and On-off
- Output Cable with Ground Wire (Optional)
- Low Inrush Current
- 100,000Hour Life @ Tc=75°C
- 5 Year Warranty @ Tc<=75°C
- Airset™ NFC Programmability
- +/-2% Output Current Accuracy
- Isolated 0-10V/PWM/Time/DALI2.0 Dimmable
- Glow-free Dim Off
- 12V 300mA Auxiliary Power to Power Controllers and Fans
- UL Class P, ENEC/CB/RCM
- Safety according to UL8750, EN 61347-1, 61347-2-13, 62384

## ■ Model List

Model Number	Input Voltage Range	Output Power	Output Voltage	Full Power Settable Current Min	Full Power Settable Current Max
SLK-800-C220-XYZ- HV0000	250~528Vac	800 W	218-500Vdc	1.6A	2.2A
	180~250Vac	640W	218-400Vdc	1.6A	2.2A
SLK-800-C280-XYZ- HV0000	250~528Vac	800 W	171-364Vdc	2.2A	2.8A
	180~250Vac	640W	171-291Vdc	2.2A	2.8A
SLK-800-C320-XYZ- HV0000	250~528Vac	800 W	150-286Vdc	2.8A	3.2A
	180~250Vac	640W	150-229Vdc	2.8A	3.2A

XY=	Dimming Method	Programmable	12Vaux	Dim-off
EN	0-10V/PWM/Time/Resistor	Cable	300mA	√
ER	0-10V/PWM/Time/Resistor	NFC Wireless	300mA	√
AR	DALI2.0	NFC Wireless	-	√
MR	RDM + DMX	NFC Wireless	-	√

Z=	U	V	S	W	D
Input Cable	3 pin UL cable with ground	3 pin UL cable with ground	3 pin VDE cable with ground	3 pin VDE cable with ground	2 pin VDE cable without ground
Output Cable	2 pin UL cable without Ground	3 pin UL cable with ground	2 pin VDE cable without ground	3 pin VDE cable with ground	2 pin VDE cable without ground
Certified with	UL Listed Class P FCC 200-480Vac	UL Listed Class P FCC 200-480Vac	ENEC CB RCM Class I 220-400Vac	ENEC CB RCM Class I 220-400Vac	Class II 220-400Vac

## ■ Technical Data

Input Voltage	180~528Vac
Input Frequency	47~63Hz
Power Factor	>0.9@60-100%load, refer to PF vs. Load curve
THD	<15%@60-100%load, refer to THD vs. Load curve
Input Current	3.0 Amax@277Vac & Full-Load 1.8 Amax@480Vac & Full-Load
Inrush Current	See Inrush Current Section in the datasheet
Leakage Current	0.75MIU max @480Vac 60Hz, UL8750 0.7mA max @400Vac 50/60Hz, IEC60598-1
Input Under Voltage	Shut down and auto-restart
Surge Protection	Line to line 6kV, line to ground 10kV, IEC 61000-4-5
Current Accuracy	±2%Io
Ripple Current	Ip <sub>pk-pk</sub> : low frequency (<=3kHz) 1%Io typ., 2%Io max. high frequency (>3kHz) 12%Io typ., 15%Io max.
TLA (Temporal Light Artifacts)	PstLM<0.02, SVM<0.05, IEC-61547-1
Percent Flicker	1% max. Broadcasting level, GB/T-38539-2020
Setup Time	1.5s max
Overshoot	10% Io max & LED Load
Output Over Voltage	110% Vomax, typ.
Short Circuit	Auto recovery. The output recovers when short is removed.
Over Temperature	Lower the output current when $T_c \geq 105 \pm 10^\circ\text{C}$ ; Auto Recovery When $T_c \leq 70 \pm 10^\circ\text{C}$
Auxiliary Power (Vaux)	12V+/-5%, 300mA max
Operating Temperature	Case Temperature $T_c = -40^\circ\text{C} \sim +90^\circ\text{C}$ ; 10%RH ~ 100%RH
Storage Temperature	-40°C ~ +85°C ; 5%RH ~ 100%RH
MTBF	≥320,000 hours, 75°C case temperature (MIL-HDBK-217F)
Lifetime	≥100,000 hours, 75°C case temperature, refer to life vs. Tc curve
Case Temperature	90°C max, marked in the Tc point of label
Dimension	207x 125 x 49 by mm (body), 232 x 125 x 49 by mm (endcaps included)
Net Weight	2270g
Packing	See Package Information Section in the datasheet

Notes: Unless specified, all the test results are measured in 25°C room temperature.

## ■ Safety/EMC Compliance

Safety Standards	Description
UL8750	Light emitting diode(LED) equipment for use in lighting products
UL1012	Power units other than class 2
IEC 61347-1	Lamp control gear Part 1: general and safety requirements
IEC 61347-2-13	Lamp control gear Part 2-13: particular requirement for d.c. or a.c. supplied electronic control gear for LED modules
IEC 62384	DC or AC supplied electronic control gear for LED modules - Performance requirements
IEC 55015/FCC Part 15	Conducted emission test & radiated emission test; ANSI C63.4:2009 Class B
IEC 61000-3-2	Harmonic current emissions; Class C
IEC 61000-3-3	Voltage fluctuations & flicker
IEC 61000-4-2	Electrostatic discharge (ESD): 8 kV air discharge, 4 kV contact discharge
IEC 61000-4-3	Radio frequency electromagnetic field susceptibility test (RS)
IEC 61000-4-4	Electrical fast transient (EFT)
IEC 61000-4-5	Surge immunity test
IEC 61000-4-6	Conducted radio frequency disturbances test (CS)
IEC 61000-4-8	Power frequency magnetic field test
IEC 61000-4-11	Voltage dips
IEC 61547	Electromagnetic immunity requirements applies to lighting equipment

## ■ Dimming

Parameter	Min.	Typ.	Max.
Vdim Sourcing Current	100uA	150uA	200uA
Vdim Allowed Input Voltage	-20 V		20 V
0-10V Dimming Range	10% (Vdim=1V)	Linear	100% (Vdim=9~10V)
PWM Dimming Range	10% (Duty=10%)	Linear	100% (Duty=90-100%)
Default Dim off Threshold	0.4V or 4%	0.5V or 5%	0.6V or 6%
Default Dim off Threshold	0.6V or 6%	0.7V or 7%	0.8V or 8%
PWM High	3.8V		9V
PWM Low	0V		0.6V
PWM Frequency	300Hz		2kHz
DA1 Interface Standard	IEC62386, part 101,102,207		
DA1,DA2 High Level	9.5	16	22.5
DA1,DA2 Low Level	-6.5	0	6.5
DA1,DA2 Current	0		2mA
DMX+ & DMX- Voltage	-6V		6V
DMX to Ground Resistance	25Mohm		
Logic 0/1 (DMX+ to DMX-) Threshold		0.2V	
Communication Baud Rate		250kbps	
Fast Dimming On-Off Transition		50ms	
Fast Dimming 10-100% Io Transition		30ms	

**- Quick Flashing**

Parameter	Min.	Typ.	Max.
0-10V Dimming Models	-	-	30fps
DALI and DMX Dimming Models	-	-	44fps

**- Default Dimming Curves**

**a. 0-10V dimming without dim-off**

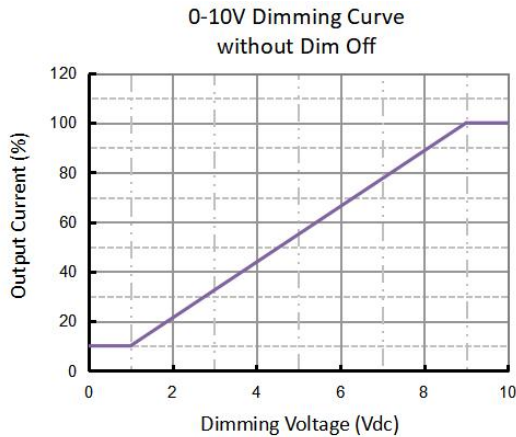

**b. 0-10V dimming with dim-off**

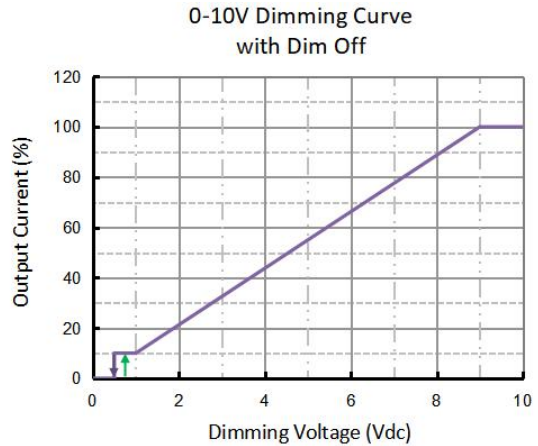

**c. DALI and DMX dimming curves**

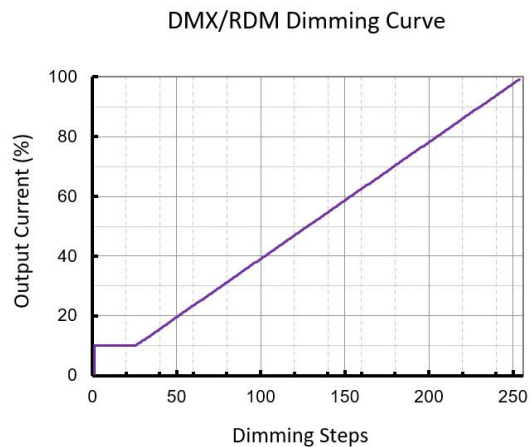
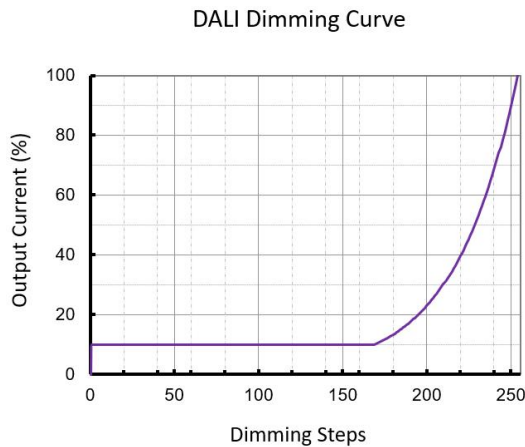

Note: Both DALI and DMX dimming curves can be customized to be linear or logarithmic as default.

## ■ Programming

### - Programmable Functions

uPowerTek LED drivers offer a range of configurable functions to meet specific lighting requirements. The Output Current, Dimming Mode, Dim Off/On Voltage Threshold, and Timer Dimming can be set as basic programming functions. Constant Lumen Output (CLO) can also be customized to ensure consistent light performance. Additionally, depending on the different product model numbers, users can benefit from programming Thermal Protection by external NTC (with extra cable), DALI/D4i Features, and DMX addressing.

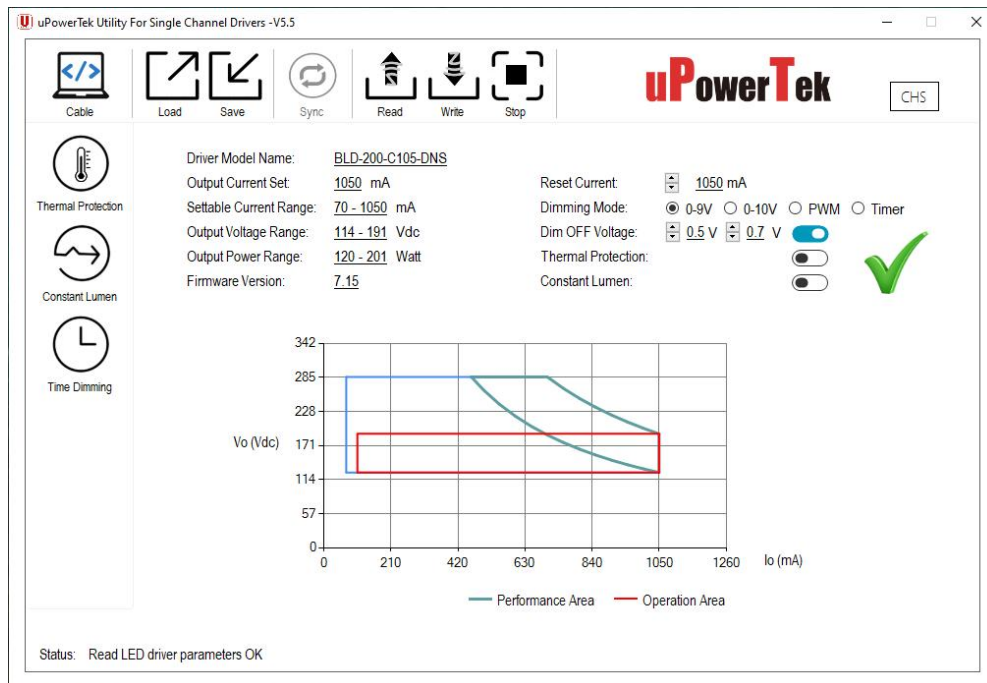

uPowreTek Programming Software Interface

### - Required Equipment

To program uPowerTek LED drivers, users will need specific equipment based on their preferred method. For wired programming, the uPowerTek Cable Programmer is essential. For NFC wireless programming, users can use a smartphone with either IOS or Android, the uPowerTek NFC Programmer, or the FEIG NFC Programmers. These tools ensure a seamless and efficient setup process, realizing precise customization of the LED driver settings.



Cable Programmer



NFC Programmer V1



NFC Programmer V2



FEIG NFC Programmer



Android or iPhone

## 800W, 200-480Vac Input, Non-isolated LED Driver

### - Connection Guide

This guide provides simple connection diagrams to help users understand the programming system. For more detailed operating instructions, including step-by-step procedures and additional configurations, please visit our website. You can download the comprehensive user manual and necessary software from the following link:

<https://www.upowertek.com/download-2/>.

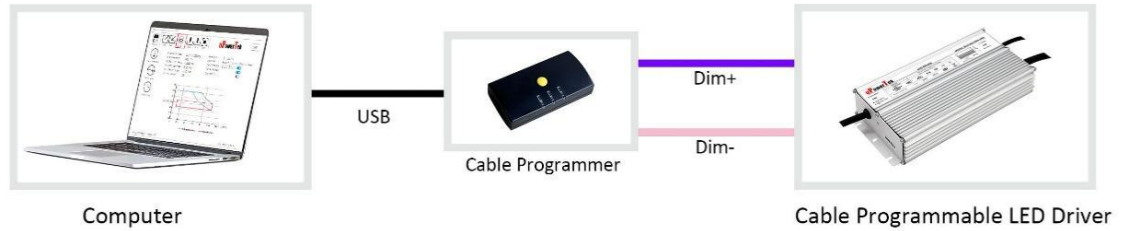

Wired Programming



Wireless Programming



Cellphone Programming

■ Lifetime vs. Case Temperature

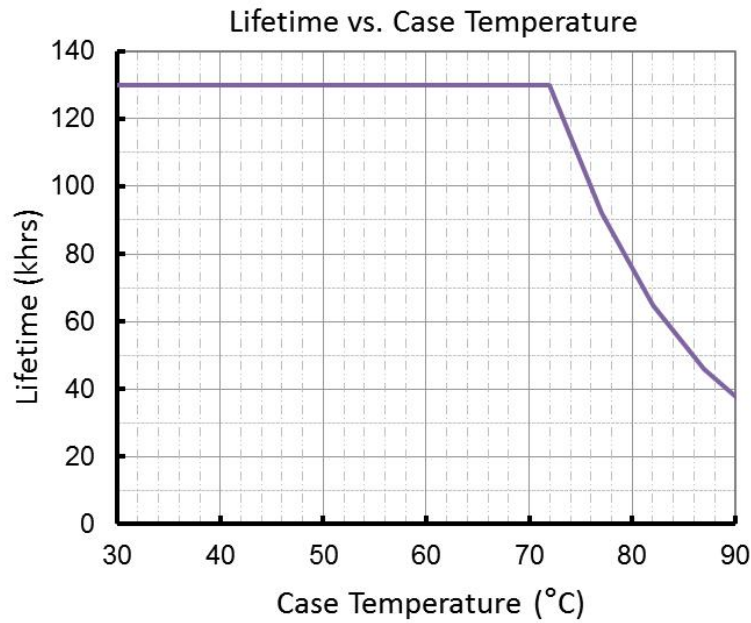

(End of Life: Maximum Failure Rate=10%)

■ Power Factor vs. Load

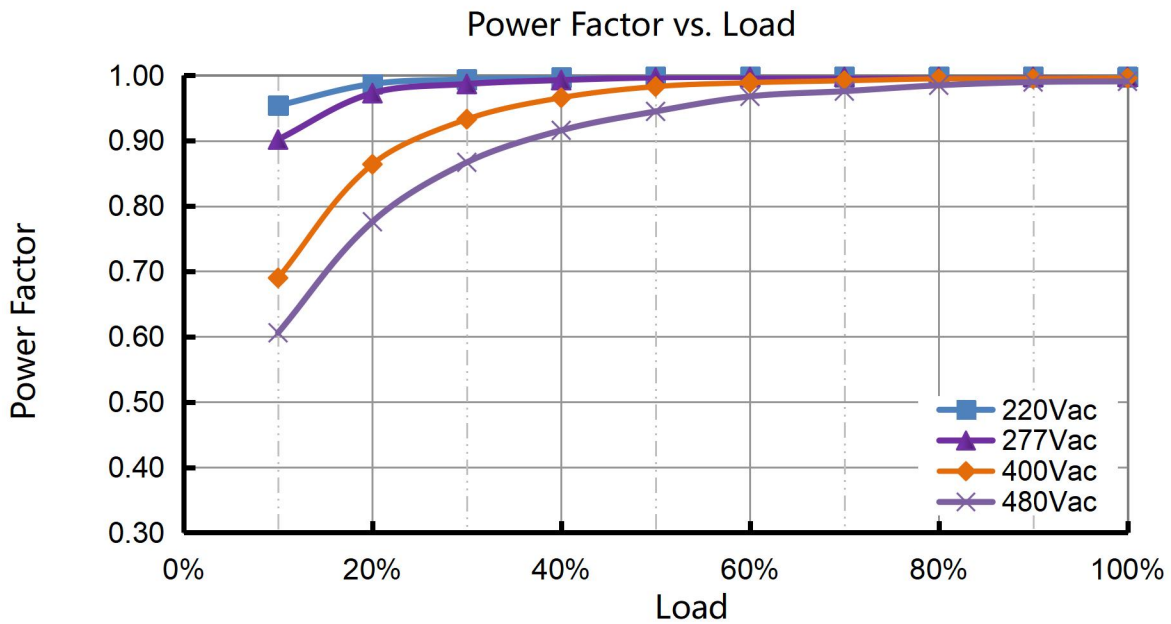

## THD vs. Load

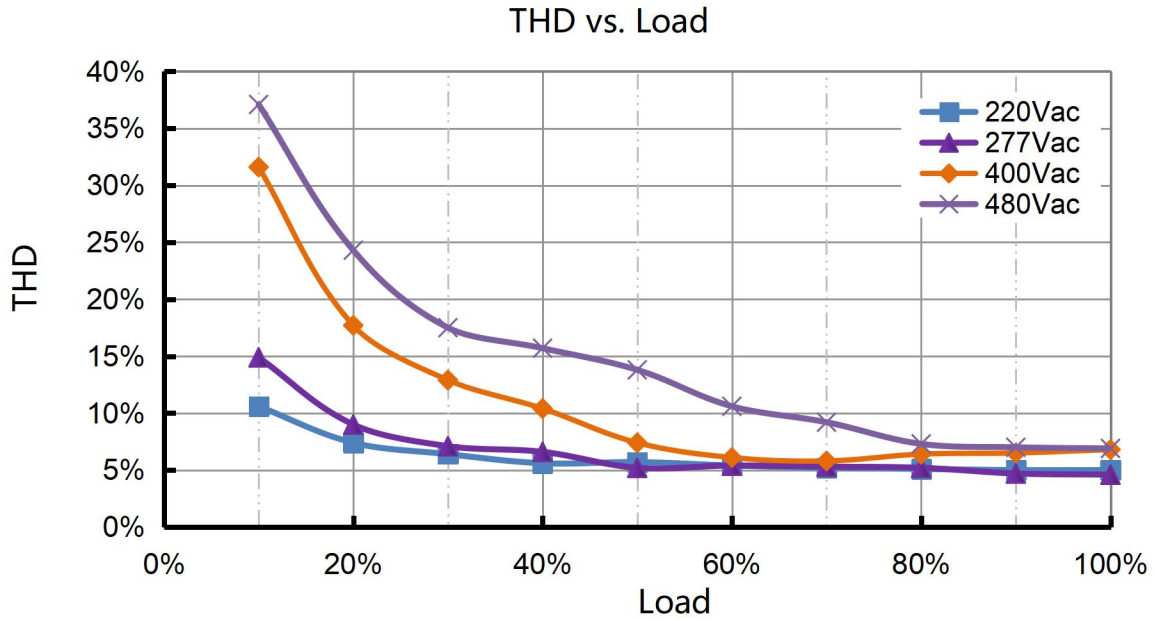

## Efficiency vs. Load

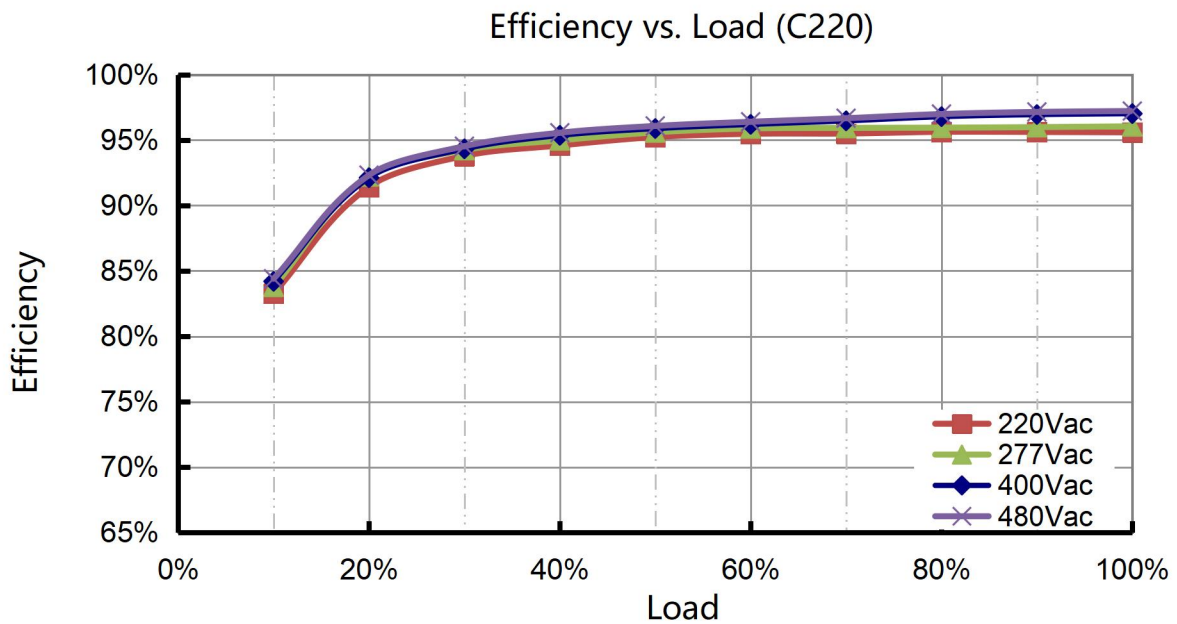

### Efficiency vs. Load (C280)

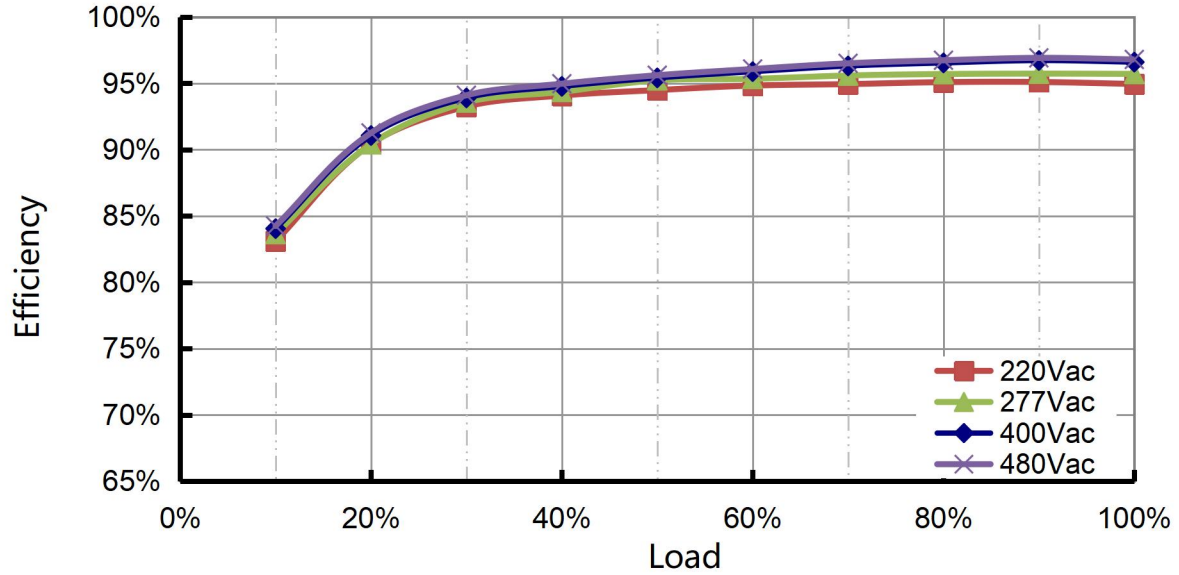

### Efficiency vs. Load (C320)

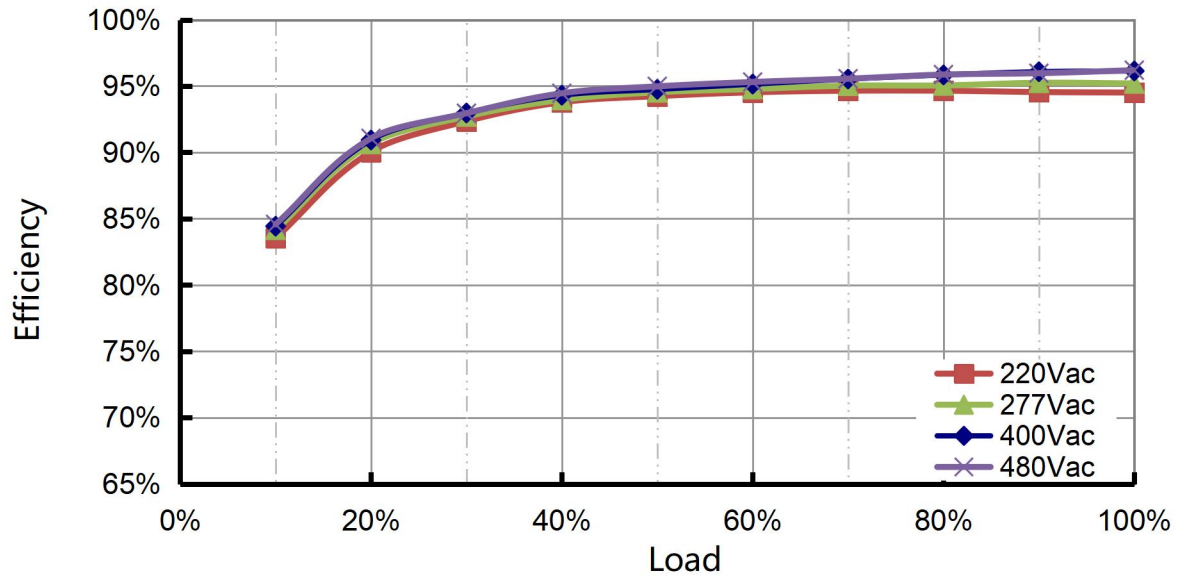

## Inrush Current

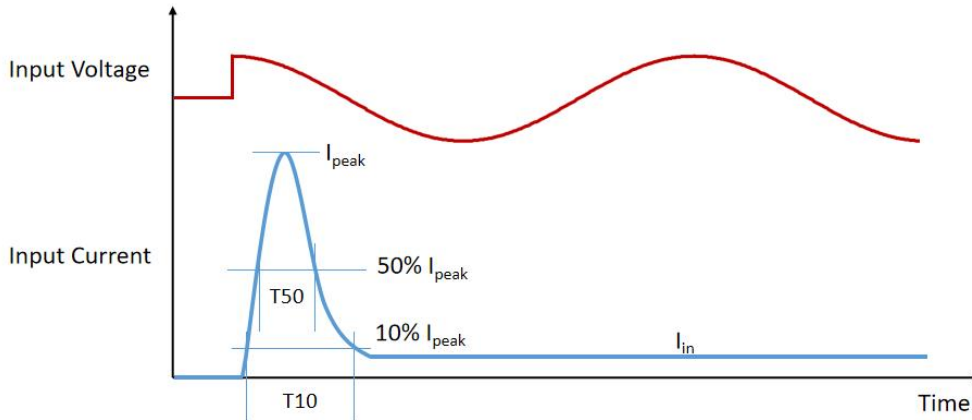

Input Voltage	$I_{peak}$	10% -10% T10 Duration	50% -50% T50 Duration
220Vac	5.4A	18.4ms	8ms
277Vac	7.1A	18ms	7.5ms
400Vac	13.3A	15.4ms	7ms
480Vac	15.3A	15.4ms	7ms

## - MCB Suggestion

Type	B10	B16	B25	B32	C10	C16	C25	C32	D10	D16	D25	D32
220Vac	1	2	3	5	1	2	4	5	2	3	5	6
277Vac	1	3	4	6	2	3	5	7	2	4	6	8
400Vac	1(x3)	2(x3)	3(x3)	5(x3)	1(x3)	2(x3)	4(x3)	5(x3)	2(x3)	3(x3)	5(x3)	6(x3)
480Vac	1(x3)	3(x3)	4(x3)	6(x3)	2(x3)	3(x3)	5(x3)	7(x3)	2(x3)	4(x3)	6(x3)	8(x3)

Three phase wiring suggestion.

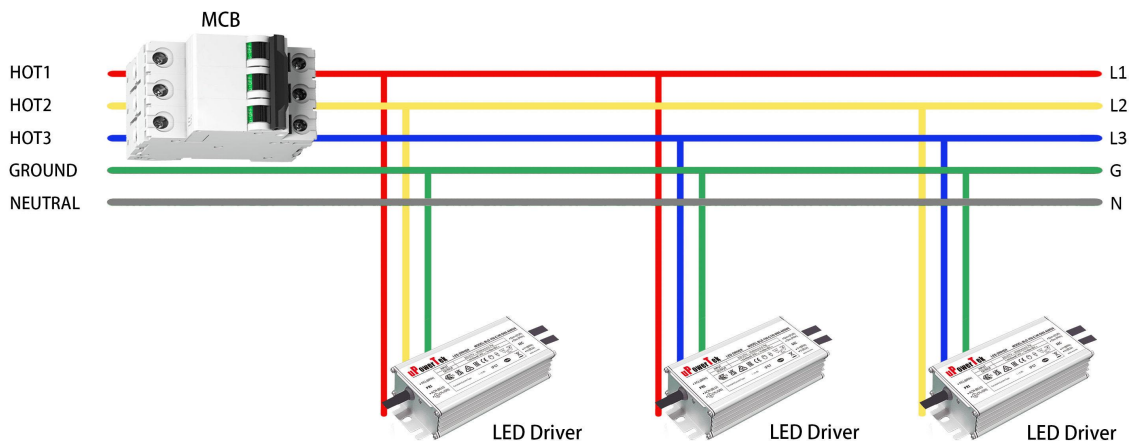

## ■ Dielectric Strength

Unit: Vac	Input	Output	Dimming	Case
Input	-	-	3920	1960
Output	-	-	3920	1960
Dimming	3920	3920	-	1960
Case	1960	1960	1960	-

## ■ Tc Point

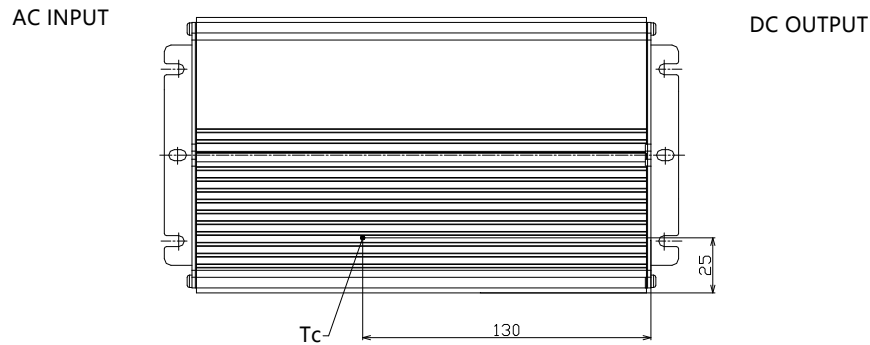

## ■ Packaging Information

Typical Carton Dimension(L×W×H)	360×300×145 mm
Positioning plate	2pcs/carton
Shield Board	1pcs/carton
LED Drivers/LED	4pcs/carton
Net Weight	9.1 kg/carton
Gross Weight	9.7 kg/carton

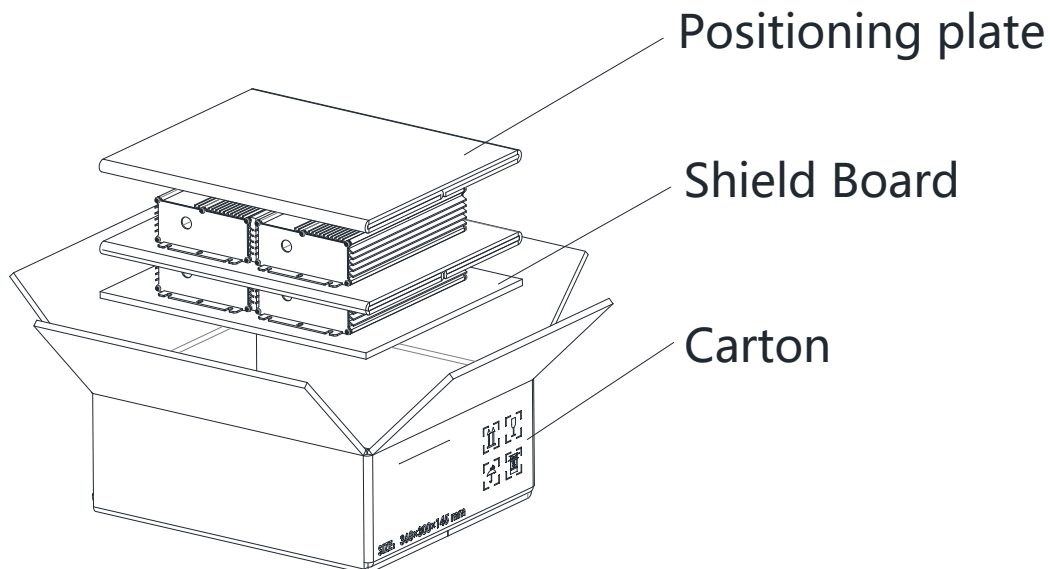

## Mechanical Design

### SLK-800-Cxxx-EN/ERU (UL Cable)

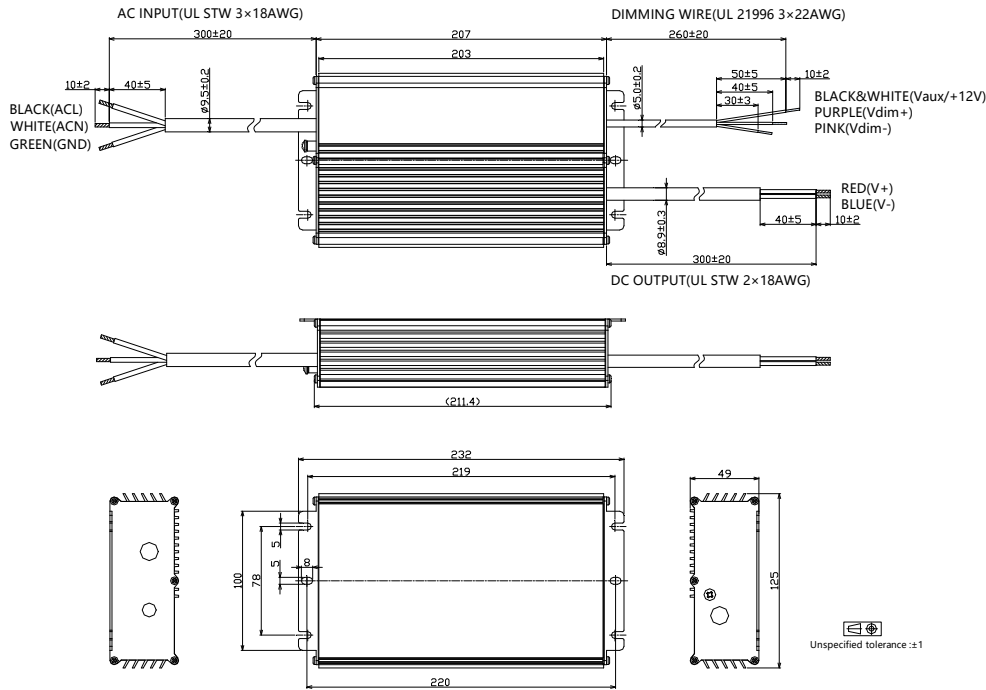

### SLK-800-Cxxx-ARU (UL Cable)

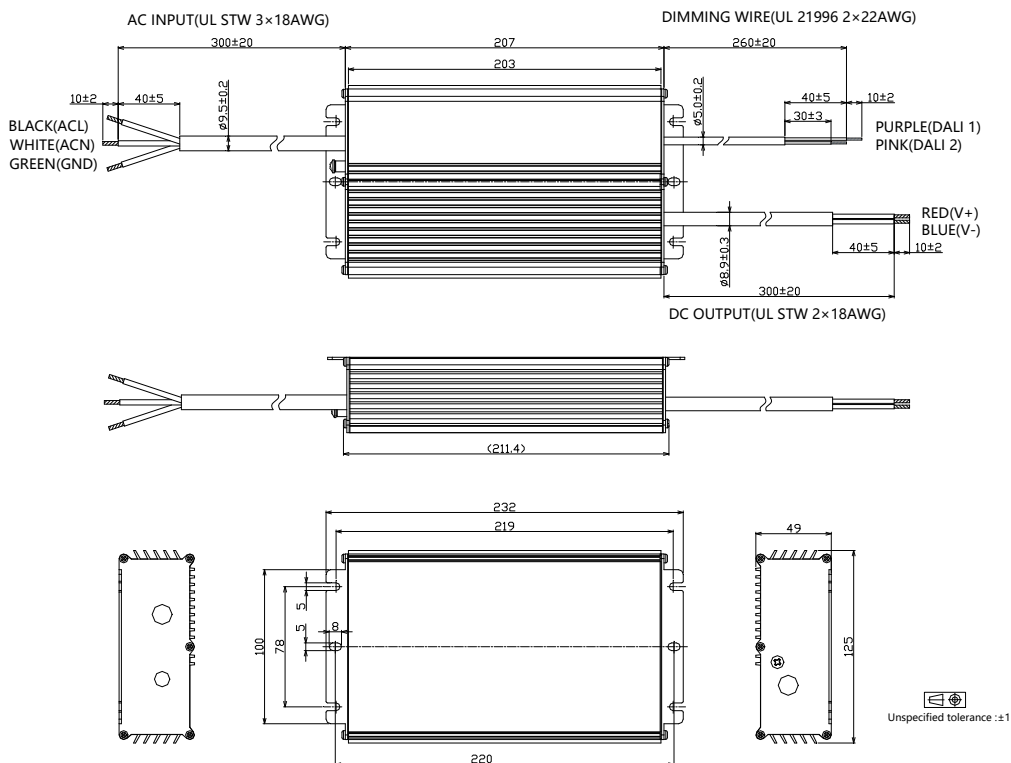

## 800W, 200-480Vac Input, Non-isolated LED Driver

### - SLK-800-Cxxx-MRU (UL Cable)

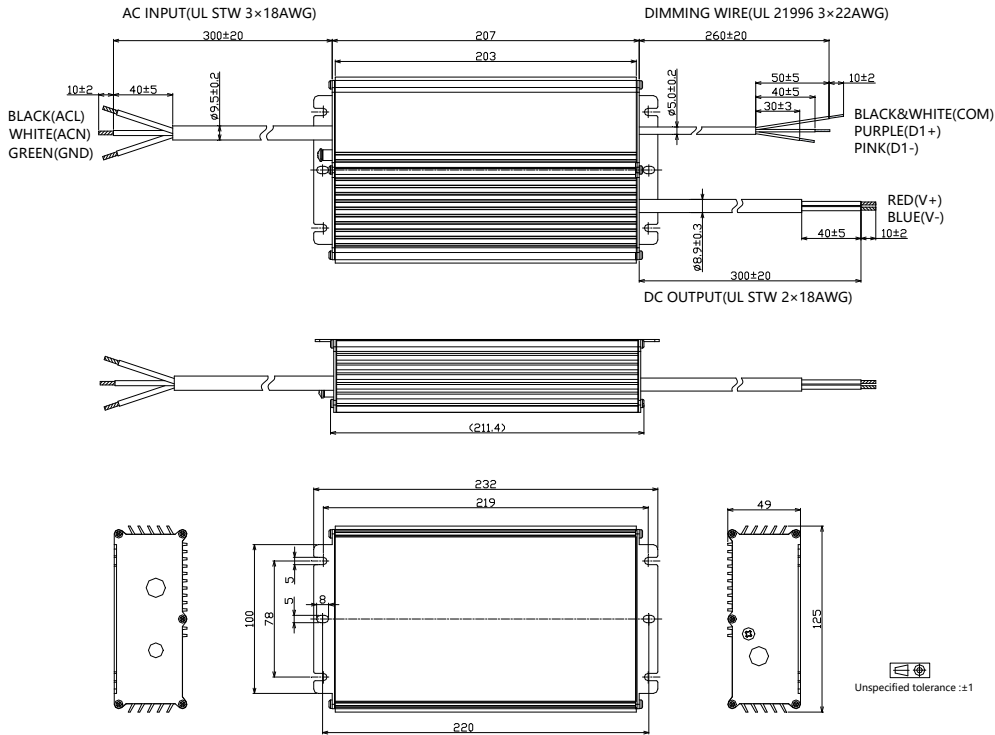

### - SLK-800-Cxxx-EN/ERS (VDE Cable)

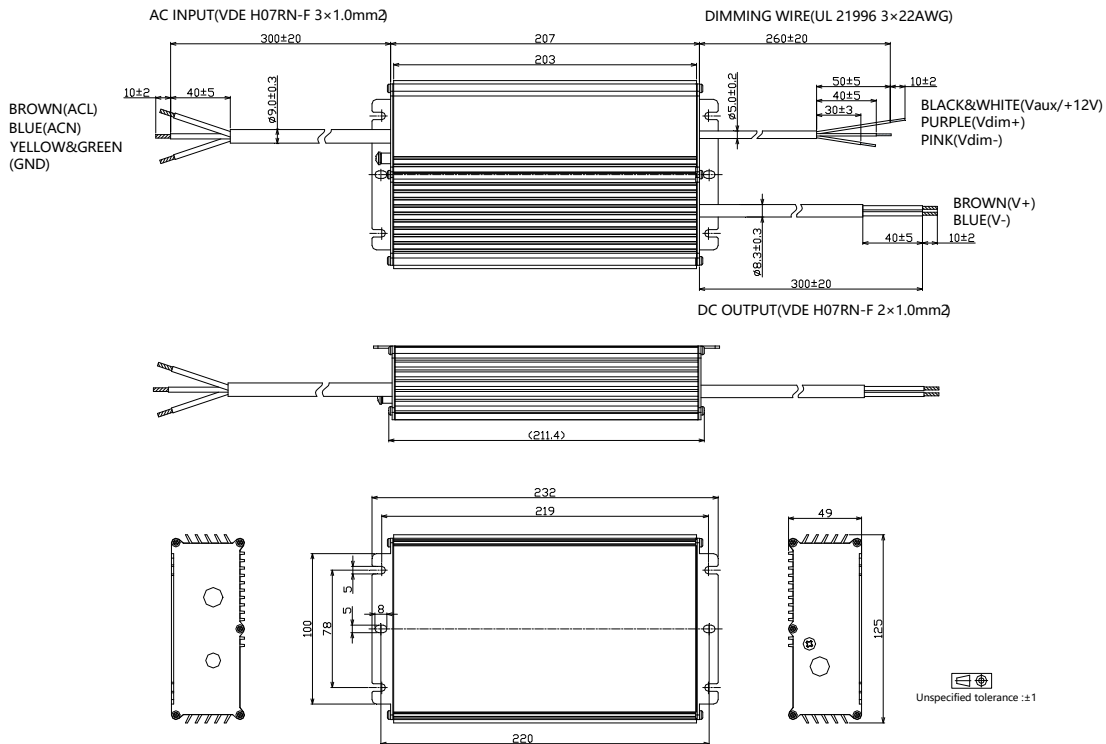

## 800W, 200-480Vac Input, Non-isolated LED Driver

### - SLK-800-Cxxx-ARS (VDE Cable)

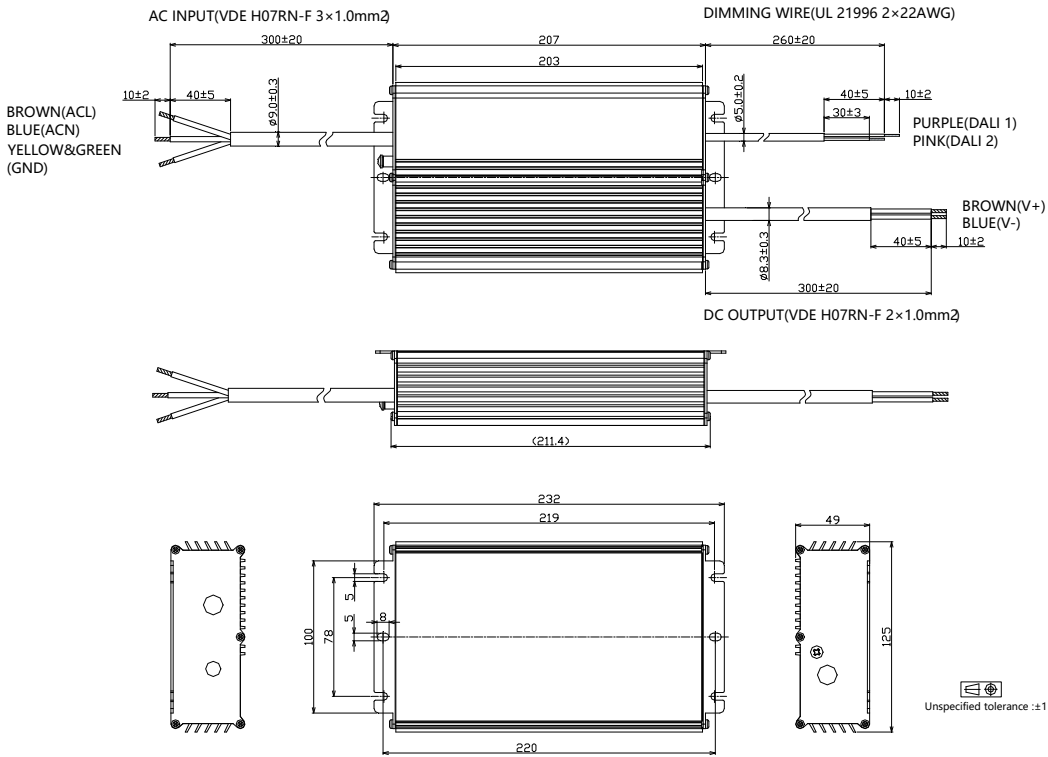

### - SLK-800-Cxxx-MRS (VDE Cable)

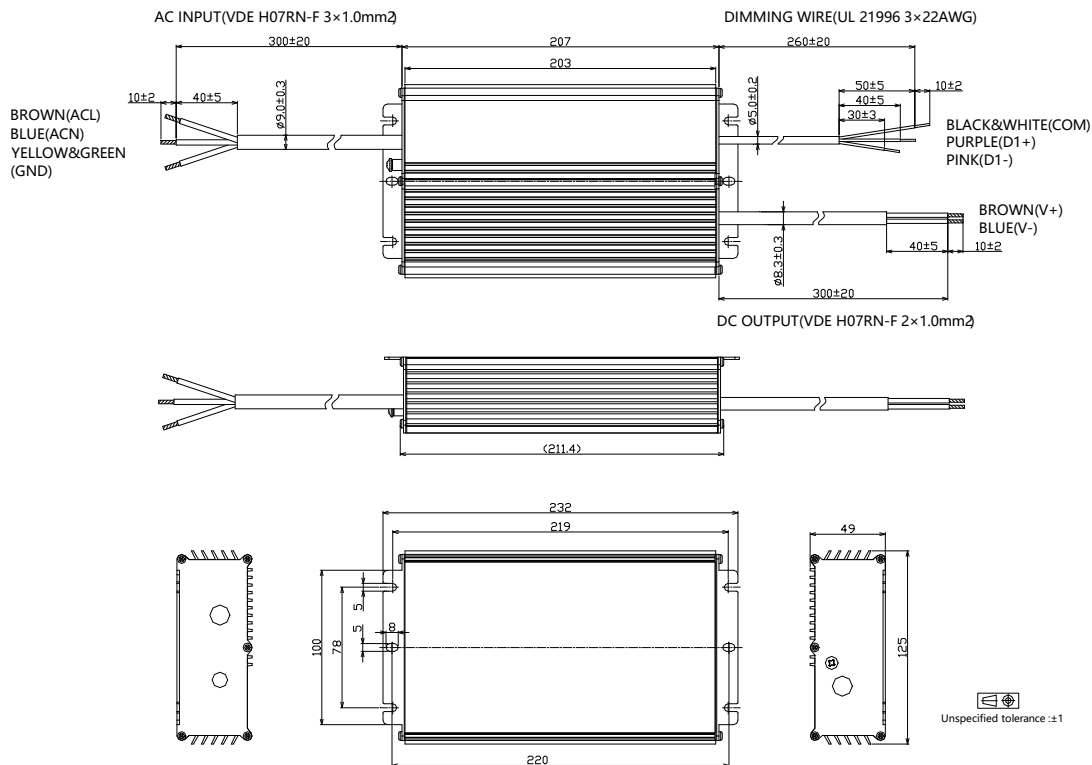

### ■ Output Operation Range

Model	Typical Set Output Current (mA)	Max Output Power (W)	Output Voltage Min (V)	Output Voltage Max(V)	Minimum Dimming Current (mA)
-C220	2200	800	218	364	220
	2100	800	229	381	210
	2000	800	240	400	200
	1900	800	253	421	190
	1800	800	267	444	180
	1700	800	282	471	170
	1600	800	300	500	160
	1500	750	300	500	160
	1400	700	300	500	160
	1300	650	300	500	160
	1200	600	300	500	160
	1100	550	300	500	160
	...	...	...	...	...
	160	80	300	500	160

Model	Typical Set Output Current (mA)	Max Output Power (W)	Output Voltage Min (V)	Output Voltage Max(V)	Minimum Dimming Current (mA)
-C280	2800	800	171	286	280
	2700	800	178	296	270
	2600	800	185	308	260
	2500	800	192	320	250
	2400	800	200	333	240
	2300	800	209	348	230
	2200	800	218	364	220
	2100	764	218	364	220
	2000	727	218	364	220
	1900	691	218	364	220
	1800	655	218	364	220
	1700	618	218	364	220
	...	...	...	...	...
	220	80	218	364	220

## 800W, 200-480Vac Input, Non-isolated LED Driver

Model	Typical Set Output Current (mA)	Max Output Power (W)	Output Voltage Min (V)	Output Voltage Max(V)	Minimum Dimming Current (mA)
-C320	3200	800	150	250	320
	3100	800	155	258	310
	3000	800	160	267	300
	2900	800	166	276	290
	2800	800	171	286	280
	2700	771	171	286	280
	2600	743	171	286	280
	2500	714	171	286	280
	2400	686	171	286	280
	2300	657	171	286	280
	2200	629	171	286	280
	2100	600	171	286	280
	...	...	...	...	...
	280	80	171	286	280

## ■ Revision History

Revision	Date	Contents
A	2022-08-22	1. First Release
B	2022-11-04	1. Tc point, packaging information updated
C	2022-12-14	1. DMX dimmable models mechanical design updated
D	2023-02-10	1. New models added
E	2023-7-14	1. Update cable selection table in Model List Section
F	2023-12-01	1. Update PF THD and Eff. curves
G	2024-07-16	1. Fast dimming and quick flashing description added 2. Ripple current spec, PstLm, SVA and Percentage Flicker added 3. Power factor, THD, efficiency curves updated by 10-100% load range 4. MCB usage and driver quantity section added 5. Inrush current data updated